

2-way proportional throttle valve for block installation

RE 29209/04.07
Replaces: 07.05

1/16

Types FES; FESE

Sizes 25 to 63
Component series 3X
Maximum operating pressure 315 bar
Maximum flow 1800 l/min at $\Delta p = 10$ bar



H4538

Table of contents

Contents	Page
Features	1
Ordering code	2
Standard types	2
Symbols	2
Function, section	3
Technical data	4, 5
Control electronics	5, 8
Electrical connection, cable socket	6, 7
Characteristic curves	9 to 14
Unit dimensions	14, 15
Installation dimensions	16

Features

- Pilot operated 2-way proportional throttle valve for block installation
- Installation dimensions to DIN ISO 7368
- Orifice spool electrically closed-loop position controlled
- Flow in both directions
- In the event of a power failure, cable break or withdrawal of the enable, the orifice spool automatically moves to the seated position and blocks the flow in both directions
- Can be used in conjunction with a pressure compensator for pressure-compensated flow control
- Type FES for external control electronics (separate order), see page 5
- Type FESE: completely matched unit with integrated electronics (OBE), optionally available with voltage or current interface

Information on available spare parts:
www.boschrexroth.com/spc

Ordering code

FES			C	A-3X/				*
-----	--	--	---	-------	--	--	--	---

For external control electronics = **No code**
 With integrated electronics (OBE) = **E**

Size 25 = **25**
 Size 32 = **32**
 Size 40 = **40**
 Size 50 = **50**
 Size 63 = **63**

Kit = **C**

Direction of flow

A to B (X connected to A)]
 B to A (X connected to B)] = **A**

Component series 30 to 39 = **3X**
 (30 to 39: unchanged installation and connection dimensions)

Flow characteristics "linear" ¹⁾

Size 25 up to 315 l/min = **315L**
 Size 32 up to 450 l/min = **450L**
 Size 40 up to 670 l/min = **670L**
 Size 50 up to 1400 l/min = **1400L**
 Size 63 up to 1800 l/min = **1800L**

¹⁾ Nominal flow in L/min at Δp 10 bar between ports A and B (see also hydraulic technical data on page 4)

Further details in clear text

Seal material

M = NBR seals, suitable for mineral oil (HL, HLP) to DIN 51524
V = FKM seals

Electronics interface

(see page 7)

B1 = Command value input 0 to 10 V/
 actual value output 0 to -10 V
G1 = Command value input 4 to 20 mA/
 actual value output 4 to 20 mA
No code = For FES for external control electronics

Electrical connection

For FES:

K4 = Without cable sockets, with component plug to DIN EN 175301-803 for proportional solenoid and GSA20 made by Hirschmann for position transducer
 Cable sockets – separate order, see page 6

For FESE:

K0 = Without cable socket, with component plug to DIN 43651, cable socket – separate order, see page 7

Standard types

Type	Material no.
FESE 25 CA-3X/315LK0B1M	R900973604
FESE 32 CA-3X/450LK0B1M	R900973605
FESE 40 CA-3X/670LK0B1M	R900973607
FESE 50 CA-3X/1400LK0B1M	R900954504
FESE 63 CA-3X/1800LK0B1M	R900954505

Symbols

Simplified
 FES .. CA-3X/...

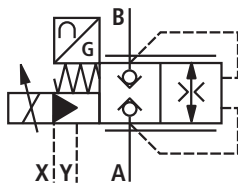

FESE .. CA-3X/...

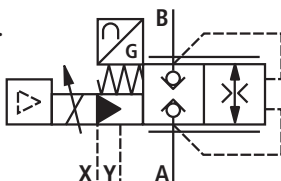

Direction of flow: A to B (X connected with A)
 B to A (X connected with B)

Detailed
 (example of FES)
 FES .. CA-3X/...

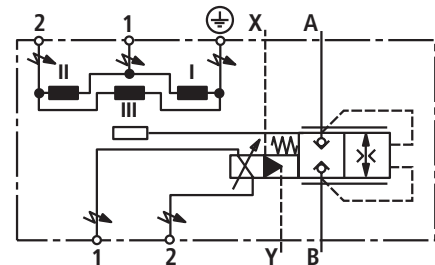

A = service port
B = service port
X = pilot oil supply
Y = pilot oil drain

Function, section

Valve types FES(E) are pilot operated 2-way proportional throttle valves for block installation for the infinitely variable control of a flow.

Technical structure:

The valve consists of four main assemblies:

- Cover (1) with mounting face for pilot oil ports.
- Main valve (2) with orifice spool (3).
- Pilot valve (4) with proportional solenoid (5).
- Integrated control electronics (6) (not provided for type FES) with position transducer (7).

General function:

- Command value-related closed-loop position control of orifice spool (3) and therefore defined opening of orifice (8).
- The flow depends on the Δp across orifice (8) and the position of orifice spool (3).
- Actual value acquisition of the position of orifice spool (3) by position transducer (7); command/actual value comparison in electronics (6); deviations are conditioned and passed on to proportional solenoid (5) of pilot valve (4) in the form of a control output for correcting the position of orifice spool (3).
- Area ratio of area (14) to area (15) = 2 : 1 for size 25; 32; 40, and 1.6 : 1 for size 50; 63.
- Direction of flow A → B (connect X with A); direction of flow B → A (connect X with B); external pilot oil supply via X possible.
- When the enable is withdrawn, orifice spool (3) moves onto valve seat (9) and closes the direction of flow A ↔ B leak-free. Spool seal (11) ensures the leak-free isolation of port B from control chamber (12); with internal pilot oil supply, take leakage oil from X via the pilot valve to Y into account!
- Orifice spool position is already controlled at a command value of 0 V or 4 mA, with orifice (8) still being in the positive overlap position.

Function of opening orifice spool:

(Assumption: flow A → B and A connected with X)

- Proportional solenoid (5) shifts pilot spool (4.1) against spring (13) and opens the connection between control chamber (12) and Y; the pressure in control chamber (12) is reduced and orifice spool (3) moved to the direction of opening by the pressure in A that acts on area (15) plus the pressure in B that acts on the annulus area (16).

Function of closing orifice spool:

(Assumption: flow A → B and A connected with X)

- Current reduced in proportional solenoid (5); spring (13) shifts pilot spool (4.1) against the proportional solenoid and opens the connection between X and control chamber (12); the pressure acting on area (14) plus spring force (10) shift orifice spool (3) in the closing direction.

Flow control function:

- In conjunction with a pressure compensator, can be used for the pressure-compensated control of a flow.

Failure of supply voltage:

- The integrated electronics de-energises the solenoid in the event of a supply voltage failure or cable break in position transducer (7).
- The spool is shifted to valve seat (9) by the pressure applied to pilot port X plus spring force (10) and blocks the flow A → B.

Type FESE .. CA-3X/...

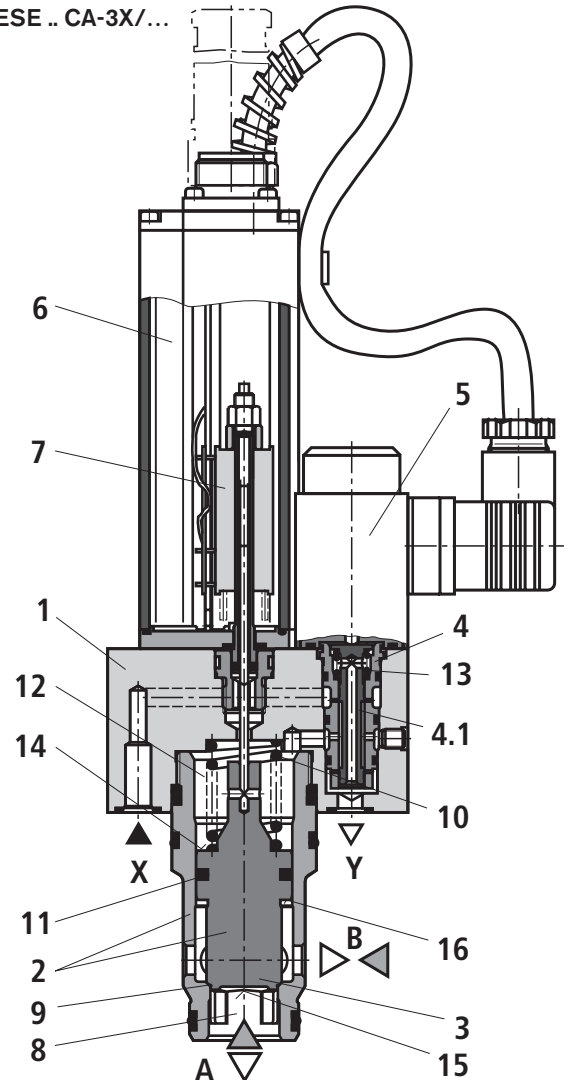

Type FES .. CA-3X/...

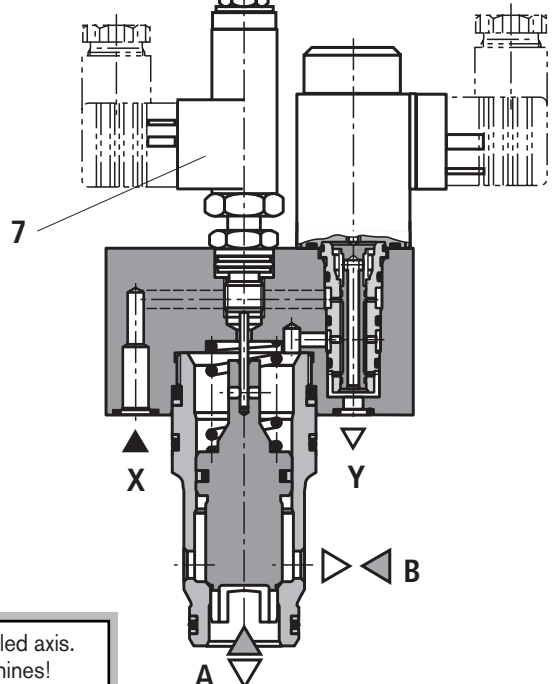

⚠ Caution: A voltage supply failure results in a sudden standstill of the controlled axis. Accelerations that can occur in conjunction with this can cause damage to machines!

Technical data (for applications outside these parameters, please consult us!)**General**

Size		25	32	40	50	63
Weight	- FES kg	3.8	5.5	8.2	12.5	21
	- FESE kg	4	5.7	8.4	12.7	21.2
Installation orientation		Optional				
Storage temperature range	°C	- 20 to + 80				
Ambient temperature range	- FES °C	- 20 to + 70				
	- FESE °C	- 20 to + 50				

Hydraulic (measured with HLP 46; $\vartheta_{oil} = 40 \text{ °C} \pm 5 \text{ °C}$)

Size	Size	25	32	40	50	63
Max. operating pressure – Ports A, B	bar	315				
Max. pilot pressure – Port X	bar	315				
Return flow pressure – Port Y		At zero pressure to tank				
Min. inlet pressure	- in A (direction of flow A → B)	12	15	15	20	20
	- in B (direction of flow B → A)	15	20	20	25	25
Max. flow q_{Vmax} of main valve at Δp 10 bar	- Direction of flow A → B	360	480	680	1400	1800
	- Direction of flow B → A	330	460	585	1400	1800
Pilot oil volume for switching process from seated position → 100%	cm ³	3.9	7.6	12	23.4	52
Max. pilot oil volume in port Y:	- With stepped input signal	5.0	6.5	10	12	17
	Pilot oil volume at control position (0 to 100% command value) from X via pilot valve to Y	< 0.3 for all sizes				
Direction of flow	- Internal pilot oil supply	A → B	Connect A to X			
		B → A	Connect B to X			
	- External pilot oil supply	A → B	Pressure at X > pressure in A			
		B → A	Pressure at X > pressure in B			
Leakage fluid	- State: Command value 0 V or 4 mA, from A → B / B → A in dependence on Δp	See characteristic curves on pages 9 to 14				
	- State: from A → X / B → X via pilot control to Y at $p = 315$ bar	< 0.3 for all sizes				
	- State: Enable inactive Solenoid de-energised ("fail-safe" position)	A → B / B → A leak-free isolation				
		⚠ Caution! In the case of internal pilot oil supply, observe leakage from A or B to X via the pilot valve to Y. $q_v < 0.2$ l/min at $\Delta p = 315$ bar With external pilot oil supply to X, this fluid loss caused by leakage from A or B can be avoided. The external pressure at X must be \geq the pressure in A with direction of flow A → B and \geq the pressure in B with direction of flow B → A.				
Hydraulic fluid		Mineral oil (HL, HLP) to DIN 51524; further hydraulic fluids on enquiry!				
Hydraulic fluid temperature range	°C	- 20 to + 80				
Viscosity range	mm ² /s	15 to 380				
Max. permissible degree of contamination of the hydr. fluid						
Cleanliness class to ISO 4406 (c)	- Pilot valve	Class 17/15/12 ¹⁾				
	- Main valve	Class 20/18/15/ ¹⁾				
Hysteresis	%	< 0.2				
Response sensitivity	%	< 0.1				
Range of inversion	%	< 0.15				

Technical data (for applications outside these parameters, please consult us!)**Type FES** – external control electronics**Electrical**, solenoid (pilot valve)

Type of voltage	V	24 DC
Nominal current	mA	1000
Coil resistance	– Cold value at 20 °C	Ω 12.7
	– Max. hot value	Ω 19.3
Duty cycle	%	100
Electrical connection	With component plug to DIN EN 175301-803	
	Cable socket to DIN EN 175301-803 ²⁾	
Type of protection of the valve to EN 60529	IP65 with cable socket mounted and locked	

Electrical, inductive position transducer (main stage; only for type FES)

Coil resistance at 20 °C (see Symbols on page 2)	Total resistance of coils between	1 and 2	2 and \perp	\perp and 1
		Ω 31.5	45.5	31.5
Inductance	mH	6 to 8		
Oscillator frequency	kHz	2.5		
Electrical connection	With component plug GSA20 made by Hirschmann			
	Cable socket GM209N (Pg9) made by Hirschmann ²⁾			
Type of protection to EN 60529	IP65 with cable socket mounted and locked			
Electrical position measuring system	Differential throttle			

Control electronics (only for type FES; separate order)

Amplifier in Euro-card format to data sheet RE 30117	Size	25	32	40	50	63
	analogue	VT-VRPA1-50	VT-VRPA1-51		VT-VRPA1-52	
Amplifier of modular design to data sheet RE 29756	analogue	VT 11037				

Type FESE – integrated electronics (OBE)**Electrical**

Current consumption– I_{\max}	A	1.3
	– Pulse load	A 1.5
Duty cycle	%	100
Electrical connection	With component plug to DIN 43651	
	Cable socket to DIN 43651 11-pin + PE/Pg16 ³⁾	
Type of protection of the valve	IP65 with cable socket mounted and locked	
Control electronics	Integrated in the valve (see page 8)	

¹⁾ The cleanliness classes specified for components must be adhered to in hydraulic systems. Effective filtration prevents malfunction and, at the same time, prolongs the service life of components.

For the selection of filters, see data sheets RE 50070, RE 50076, RE 50081, RE 50086 and RE 50088.

²⁾ Separate order, see page 6

³⁾ Separate order, see page 7

 **Note:** Details with regard to **environment simulation testing** in the fields of EMC (electromagnetic compatibility), climate and mechanical stress, see RE 29209-U (declaration on environmental compatibility).

Electrical connection, cable sockets (nominal dimensions in mm)

Type FES – for external control electronics

Connection to component plug

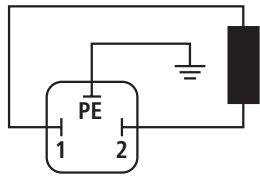

Connection to cable socket

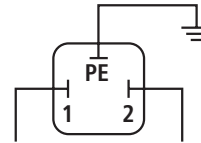

to amplifier

Cable socket to DIN EN 175301-803

Separate order stating material no. **R901017011**
(plastic version)

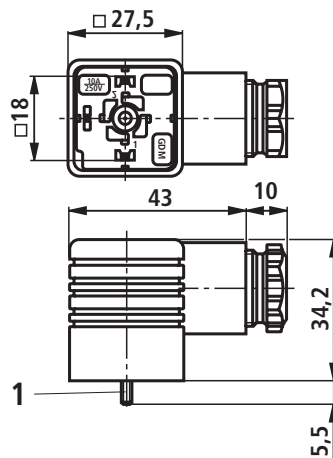

1 Fixing screw M3
Tightening torque $M_T = 0.5 \text{ Nm}$

Inductive position transducer

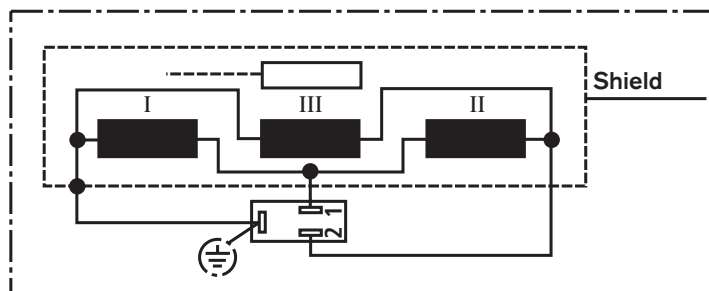

Cable socket GM209N (Pg9) made by Hirschmann

Separate order stating material no. **R900013674**
(plastic version)

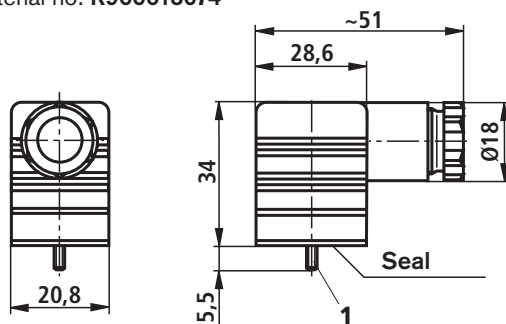

1 Fixing screw M3
Tightening torque $M_T = 0.5 \text{ Nm}$

Electrical connection, cable sockets (nominal dimensions in mm)

Type FESE – with integrated electronics (OBE)

Cable socket to DIN 43651/11-pin + PE/Pg16

Separate order stating material no. **R900884671**
(plastic version)

Assembly consisting of items 1 and 1.1 or
items 1 and 1.2, type of protection IP65

Note:

- If you use **one** cable, combine item 1 with item 1.1
- If you use **two** cables, combine item 1 with item 1.2

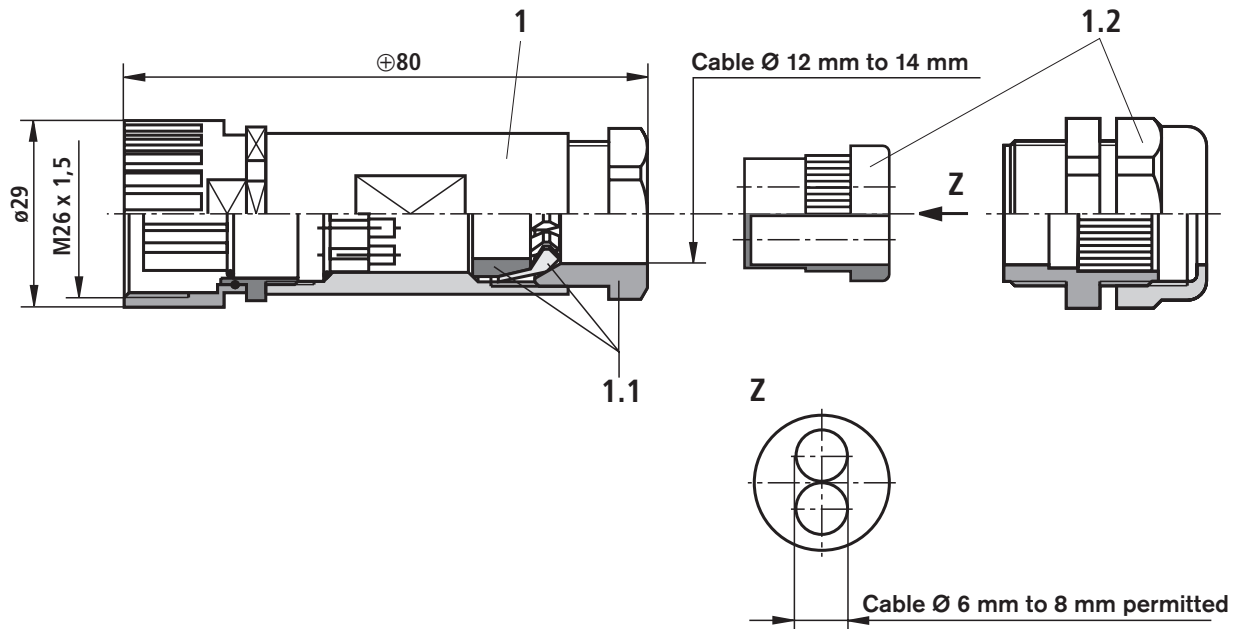

Pin	Function	Conditions		
1	Operating voltage +UL	$U_O = 24 \text{ VDC}$; $u_O(t)_{\max} = 36 \text{ V}$; $u_O(t)_{\min} = 21.6 \text{ V}$		
2	Ground L0			
3	Enable input / reference for pin 2	$\log 1 = 10 \text{ V to } 36 \text{ V}$; $\log 0 = U < 8 \text{ V}$		
		<table border="1" style="width: 100%;"> <tr> <td>Type FESE.../...B1...</td> <td>Type FESE.../...G1...</td> </tr> <tr> <td>Voltage interface</td> <td>Current interface</td> </tr> </table>	Type FESE.../...B1...	Type FESE.../...G1...
Type FESE.../...B1...	Type FESE.../...G1...			
Voltage interface	Current interface			
4	Command value input	$0 \text{ V to } +10 \text{ V}$ ($R_i > 50 \text{ k}\Omega$)		
5	Command value input, reference	$+4 \text{ mA to } +20 \text{ mA}$ / load = 100Ω		
6	Actual value output	$0 \text{ V to } -10 \text{ V}$ ($I_{\max} = 5 \text{ mA}$)		
7	Actual value output, reference	$+4 \text{ mA to } +20 \text{ mA}$ / load $\leq 500 \Omega$		
8	free			
9	free			
10	free			
11	Ready for operation (output)	Valve not ready for operation: $U_{\text{Pin11}} < 8 \text{ V}$;		
		Valve not ready for operation: $U_{\text{Pin11}} = U_O - 3 \text{ V}$		
PE	Protective conductor \perp	Reference – pin 2: (I_{\max} against 0 V ; 50 mA);		

Recommended connecting cable

- Up to 25 m → min. 0.75 mm^2 per wire
- Up to 50 m → min. 1.5 mm^2 per wire
- Connect shield to PE only on the supply side

Integrated electronics (OBE) of type FESE

Function

1. Making operation/disturbance characteristic:

After the supply voltage of 24 V was applied, the electronics is ready for operation, if the following conditions are fulfilled:

- Operating voltage $U_O > 18$ VDC
- The internal ± 7.5 V supply voltage is symmetrical
- The connection to the position transducer is not interrupted.
- The command value cable is not interrupted (only with 4 mA to 20 mA interface)

If one of these conditions is not fulfilled, the controller and the output stage are blocked and the signal "ready for operation" is set to < 8 V.

2. Normal operation

When the enable is inactive (< 8 V) and an optional command value is fed forward (0 to 10V or 4 to 20 mA) the orifice spool is in the seated position and blocks the flow from A to B.

By applying a voltage > 10 V to the enable, the position controller for the orifice spool and the output stage for the pilot valve are switched on. At the same time, the position controller (PID) compares the actual value of the orifice spool position

with the applied command value, and a control output is fed to the output stage, which changes the solenoid current until the orifice spool position corresponds to the command value.

The actual value of the orifice spool position is sensed by an inductive position transducer. The signal of the latter is rectified by the demodulator and fed back to the PID-controller.

The following output signals are available on the plug:

- Actual position value FESE.../...B1 (pin 6)
 - 0 V to -10 V corresponds to 0 % to 100 % valve opening
 - Orifice spool in seated position \rightarrow actual value > 0.8 V
- Actual position value FESE.../...G1 (pin 6)
 - 4 mA to 20 mA corresponds to 0 % to 100 % valve opening
 - Orifice spool in seated position \rightarrow actual value < 2.7 mA
- Signal "ready for operation" (pin 11)
 - All conditions listed above are fulfilled $\rightarrow > 10$ V
 - One of the conditions is not fulfilled $\rightarrow < 8$ V

Block circuit diagram / pin assignment of integrated electronics

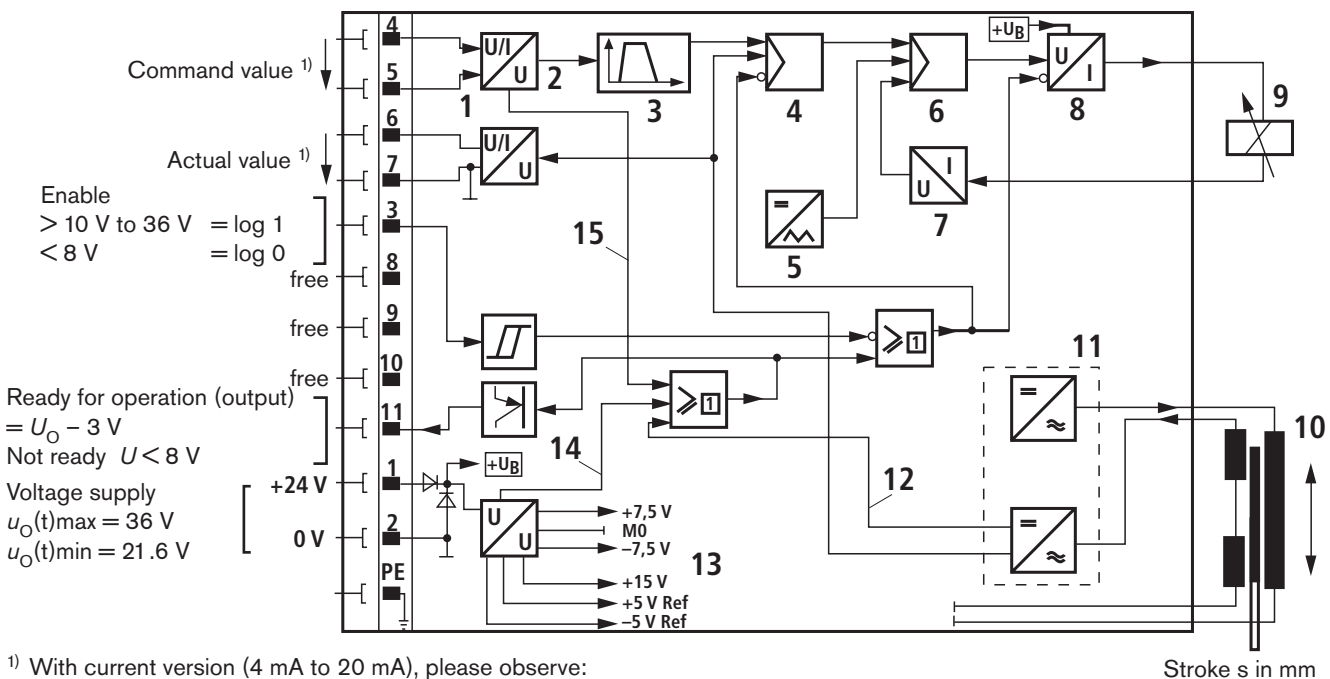

- ¹⁾ With current version (4 mA to 20 mA), please observe:
 Between connections 5 and 4, load = 100 Ω
 Between connections 6 and 7, load ≤ 500 Ω

- | | |
|-----------------------|---|
| 1 Input | 9 Proportional solenoid |
| 2 Output | 10 Position transducer |
| 3 Fixed ramp | 11 Oscillator / demodulator |
| 4 Position controller | 12 Fault signal of position transducer |
| 5 Clock pulse | 13 Power supply unit |
| 6 Current regulator | 14 Error signal in the case of $+U_O$ undervoltage and asymmetry in the power supply unit |
| 7 I/U converter | 15 Cable break signal with current command value |
| 8 Output stage | |

Characteristic curves (measured with HLP 46 and $\vartheta_{oil} = 40\text{ °C} \pm 5\text{ °C}$)

Size 25

Flow characteristic linear

FES(E) 25 C.../315L... direction of flow A → B

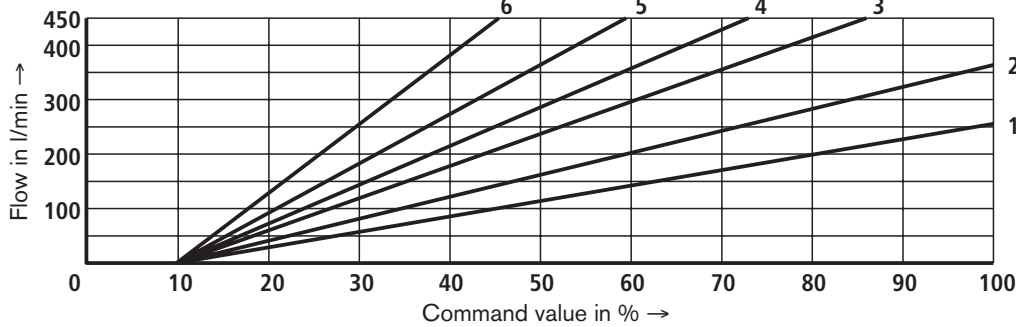

- 1 $\Delta p = 5\text{ bar}$
- 2 $\Delta p = 10\text{ bar}$
- 3 $\Delta p = 20\text{ bar}$
- 4 $\Delta p = 30\text{ bar}$
- 5 $\Delta p = 50\text{ bar}$
- 6 $\Delta p = 100\text{ bar}$

FES(E) 25 C.../315L... direction of flow B → A

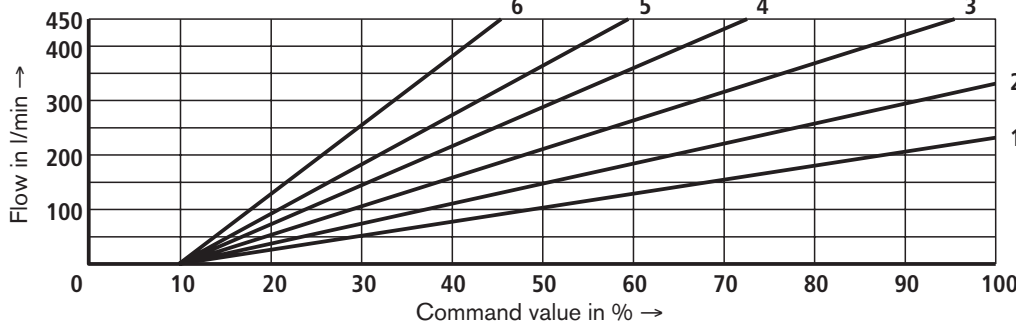

- 1 $\Delta p = 5\text{ bar}$
- 2 $\Delta p = 10\text{ bar}$
- 3 $\Delta p = 20\text{ bar}$
- 4 $\Delta p = 30\text{ bar}$
- 5 $\Delta p = 50\text{ bar}$
- 6 $\Delta p = 100\text{ bar}$

Transient function in the case of stepped command value change ¹⁾

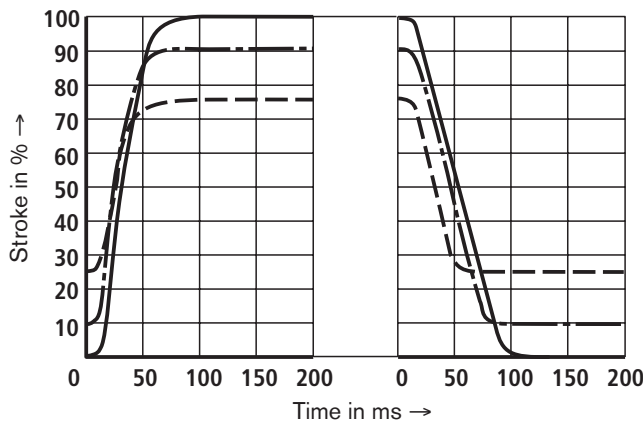

- Step responses
- 0 - 100 - 0 % ———
 - 10 - 90 - 10 % - · - · - ·
 - 25 - 75 - 25 % - - - - -

¹⁾ Measurement conditions

Pressure in A = 50 bar
 Actuator in B closed ($p_A = p_B = 50\text{ bar}$)
 Pressure in A < 50 bar → actuating time is extended
 Pressure in A > 50 bar → actuating time is shortened

The area ratio of the orifice spool has an influence on the actuating time as follows:

→ Command value 0 → 100%: The actuating time becomes shorter, the higher the inlet pressure and the smaller the Δp across the valve.

→ Command value 100 → 0%: The actuating time becomes shorter, the higher the inlet pressure and the higher the Δp across the valve.

Leakage from A → B and B → A in dependence upon the pressure differential Δp (command value 0 V or 4 mA, resp.)

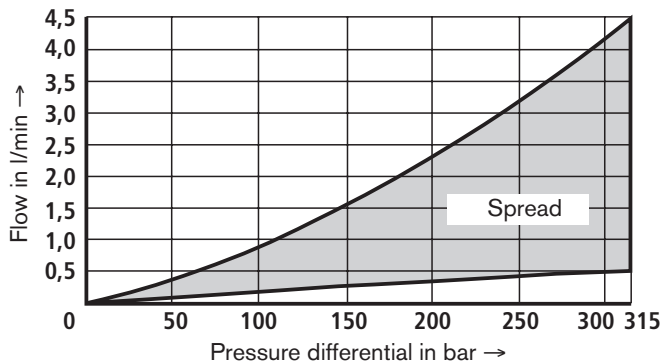

Characteristic curves (measured with HLP 46 and $\vartheta_{oil} = 40 \text{ }^\circ\text{C} \pm 5 \text{ }^\circ\text{C}$)

Size 32

Flow characteristic linear

FES(E) 32 C.../450L... direction of flow A → B

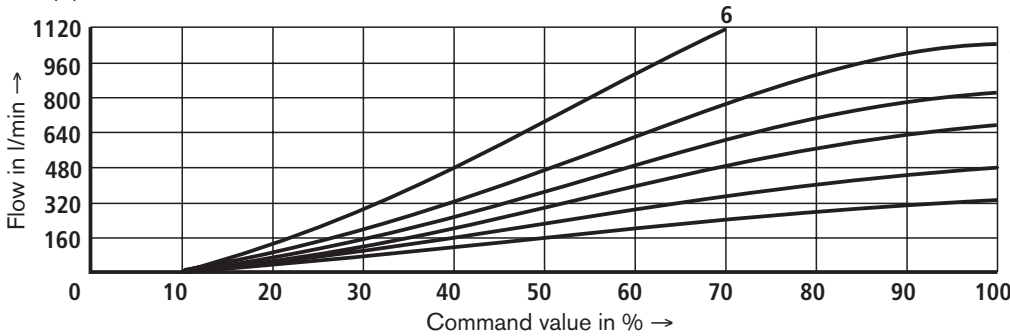

- 1 $\Delta p = 5 \text{ bar}$
- 2 $\Delta p = 10 \text{ bar}$
- 3 $\Delta p = 20 \text{ bar}$
- 4 $\Delta p = 30 \text{ bar}$
- 5 $\Delta p = 50 \text{ bar}$
- 6 $\Delta p = 100 \text{ bar}$

FES(E) 32 C.../450L... direction of flow B → A

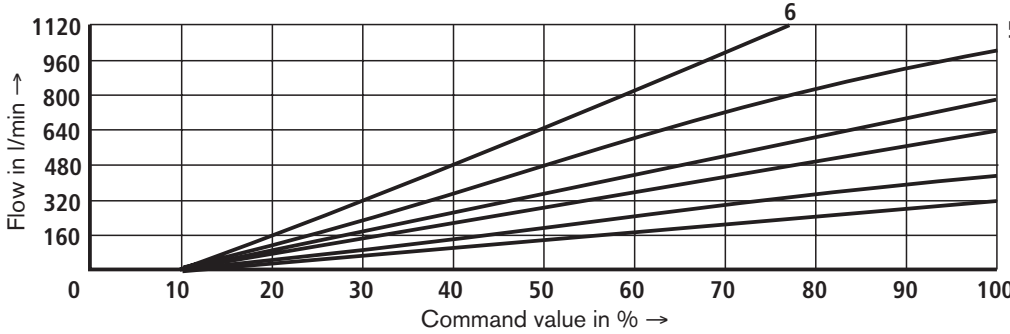

- 1 $\Delta p = 5 \text{ bar}$
- 2 $\Delta p = 10 \text{ bar}$
- 3 $\Delta p = 20 \text{ bar}$
- 4 $\Delta p = 30 \text{ bar}$
- 5 $\Delta p = 50 \text{ bar}$
- 6 $\Delta p = 100 \text{ bar}$

Transient function with stepped command value change ¹⁾

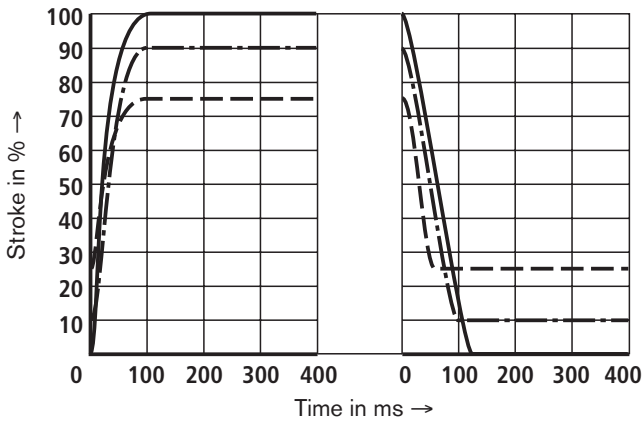

- Step responses
- 0 - 100 - 0 % ———
 - 10 - 90 - 10 % - · - · -
 - 25 - 75 - 25 % - - - -

¹⁾ Measurement conditions

Pressure in A = 50 bar
 Verbraucher in B geschlossen ($p_A = p_B = 50 \text{ bar}$)
 Pressure in A < 50 bar → actuating time is extended
 Pressure in A > 50 bar → actuating time is shortened
 The area ratio of the orifice spool has an influence on the actuating time as follows:

→ Command value 0 → 100%: The actuating time becomes shorter, the higher the inlet pressure and the smaller the Δp across the valve.

→ Command value 100 → 0%: The actuating time becomes shorter, the higher the inlet pressure and the higher the Δp across the valve.

Leakage from A → B and B → A in dependence upon the pressure differential Δp (command value 0 V or 4 mA, resp.)

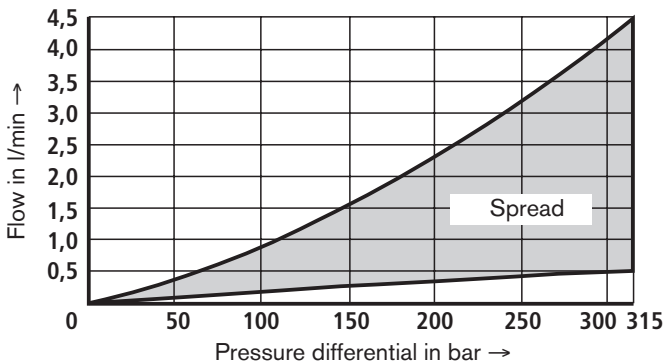

Characteristic curves (measured with HLP 46 and $\vartheta_{oil} = 40 \text{ }^\circ\text{C} \pm 5 \text{ }^\circ\text{C}$)

Size 40

Flow characteristic linear

FES(E) 40 C.../670L... Direction of flow A → B

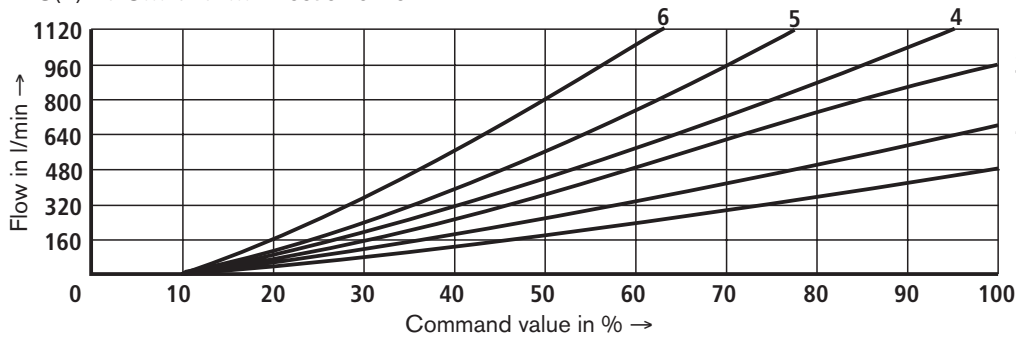

- 1 $\Delta p = 5 \text{ bar}$
- 2 $\Delta p = 10 \text{ bar}$
- 3 $\Delta p = 20 \text{ bar}$
- 4 $\Delta p = 30 \text{ bar}$
- 5 $\Delta p = 50 \text{ bar}$
- 6 $\Delta p = 100 \text{ bar}$

FES(E) 40 C.../670L... Direction of flow B → A

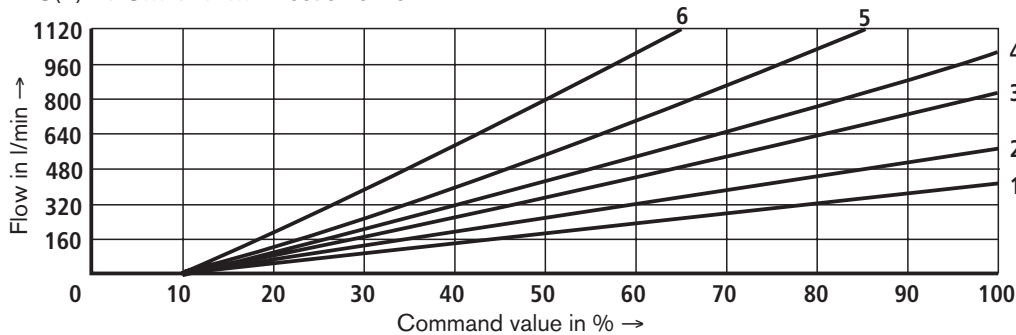

- 1 $\Delta p = 5 \text{ bar}$
- 2 $\Delta p = 10 \text{ bar}$
- 3 $\Delta p = 20 \text{ bar}$
- 4 $\Delta p = 30 \text{ bar}$
- 5 $\Delta p = 50 \text{ bar}$
- 6 $\Delta p = 100 \text{ bar}$

Transient function with stepped command value change ¹⁾

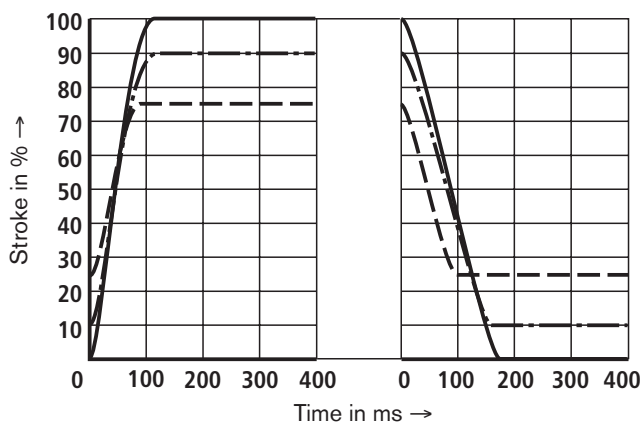

- Step responses
- 0 - 100 - 0 % ———
 - 10 - 90 - 10 % - - - -
 - 25 - 75 - 25 % - - - -

¹⁾ Measurement conditions

Pressure in A = 50 bar
 Verbraucher in B geschlossen ($p_A = p_B = 50 \text{ bar}$)
 Pressure in A < 50 bar → actuating time is extended
 Pressure in A > 50 bar → actuating time is shortened

The area ratio of the orifice spool has an influence on the actuating time as follows:

→ Command value 0 → 100%: The actuating time becomes shorter, the higher the inlet pressure and the smaller the Δp across the valve.

→ Command value 100 → 0%: The actuating time becomes shorter, the higher the inlet pressure and the higher the Δp across the valve.

Leakage from A → B and B → A in dependence upon the pressure differential Δp (command value 0 V or 4 mA, resp.)

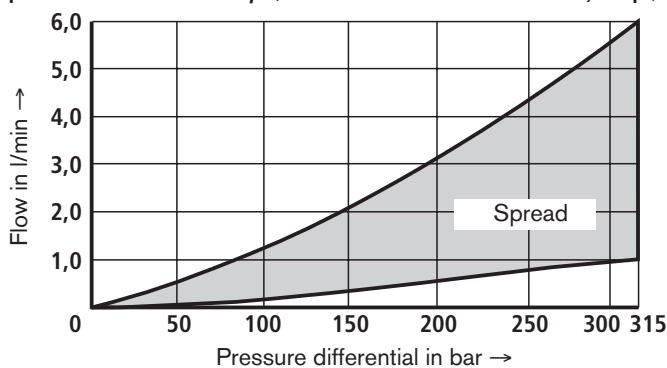

Characteristic curves (measured with HLP 46 and $\vartheta_{oil} = 40 \text{ }^\circ\text{C} \pm 5 \text{ }^\circ\text{C}$)

Size 50

Flow characteristic linear ¹⁾

FES(E) 50 C.../1400L... direction of flow A → B

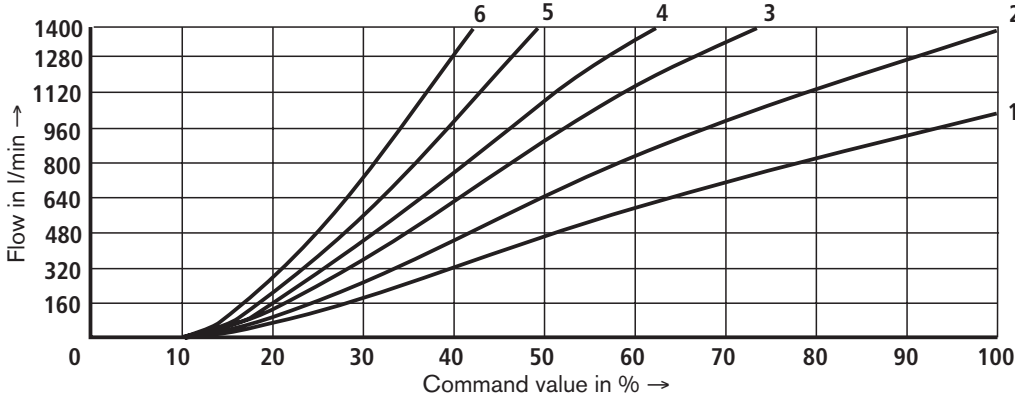

- 1 $\Delta p = 5 \text{ bar}$
- 2 $\Delta p = 10 \text{ bar}$
- 3 $\Delta p = 20 \text{ bar}$
- 4 $\Delta p = 30 \text{ bar}$
- 5 $\Delta p = 50 \text{ bar}$
- 6 $\Delta p = 100 \text{ bar}$

FES(E) 50 C.../1400L... direction of flow B → A

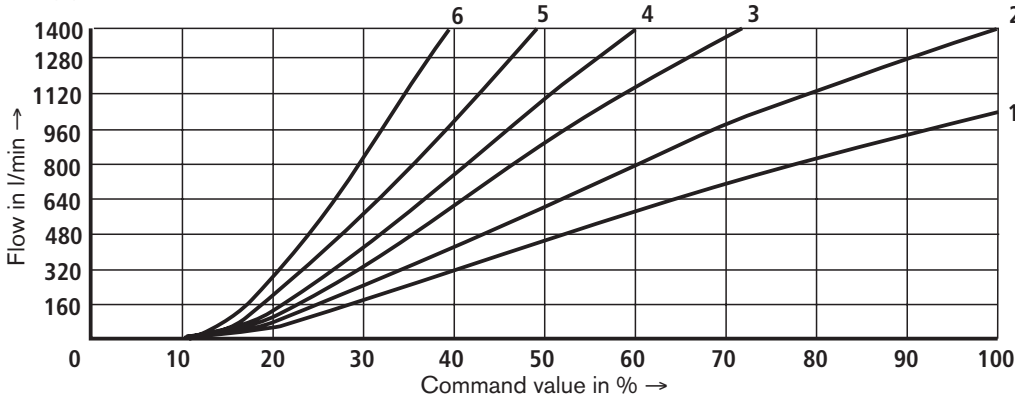

- 1 $\Delta p = 5 \text{ bar}$
- 2 $\Delta p = 10 \text{ bar}$
- 3 $\Delta p = 20 \text{ bar}$
- 4 $\Delta p = 30 \text{ bar}$
- 5 $\Delta p = 50 \text{ bar}$
- 6 $\Delta p = 100 \text{ bar}$

Transient function with stepped command value change ²⁾

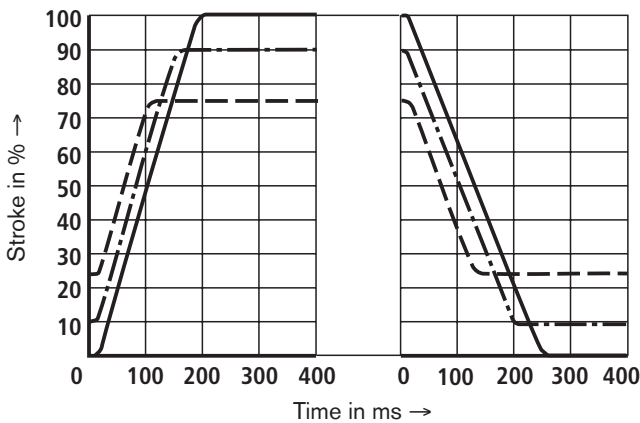

- Step responses
- 0 - 100 - 0 % ———
 - 10 - 90 - 10 % - · - · -
 - 25 - 75 - 25 % - - - -

¹⁾ Flow values above 1200 l/min are no measured values!

²⁾ Measurement conditions

- Pressure in A = 50 bar
- Verbraucher in B geschlossen ($p_A = p_B = 50 \text{ bar}$)
- Pressure in A < 50 bar → actuating time is extended
- Pressure in A > 50 bar → actuating time is shortened

The area ratio of the orifice spool has an influence on the actuating time as follows:

→ Command value 0 → 100%: The actuating time becomes shorter, the higher the inlet pressure and the smaller the Δp across the valve.

→ Command value 100 → 0%: The actuating time becomes shorter, the higher the inlet pressure and the higher the Δp across the valve.

Leakage from A → B and B → A in dependence upon pressure differential Δp (command value 0 V or 4 mA, resp.)

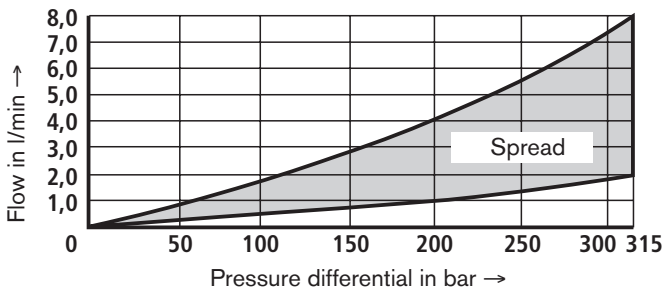

Characteristic curves (measured with HLP 46 and $\vartheta_{oil} = 40\text{ }^\circ\text{C} \pm 5\text{ }^\circ\text{C}$)

Size 63

Flow characteristic linear ¹⁾

FES(E) 63 C.../1800L... direction of flow A → B

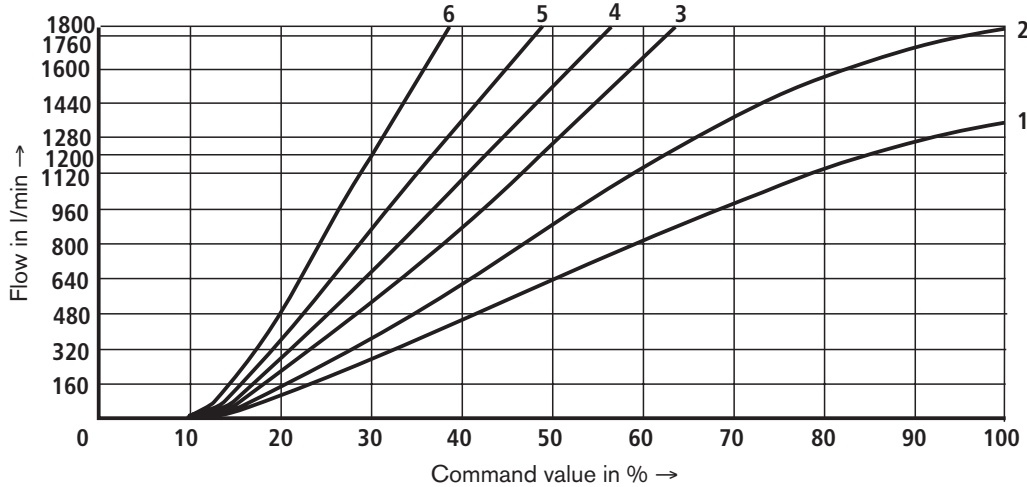

- 1 $\Delta p = 5\text{ bar}$
- 2 $\Delta p = 10\text{ bar}$
- 3 $\Delta p = 20\text{ bar}$
- 4 $\Delta p = 30\text{ bar}$
- 5 $\Delta p = 50\text{ bar}$
- 6 $\Delta p = 100\text{ bar}$

FES(E) 63C.../1800L... Direction of flow B → A

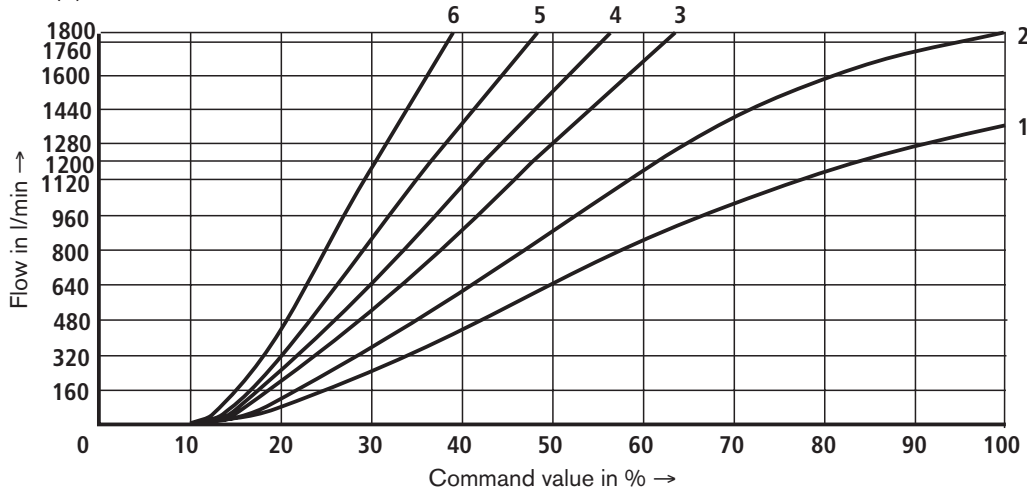

- 1 $\Delta p = 5\text{ bar}$
- 2 $\Delta p = 10\text{ bar}$
- 3 $\Delta p = 20\text{ bar}$
- 4 $\Delta p = 30\text{ bar}$
- 5 $\Delta p = 50\text{ bar}$
- 6 $\Delta p = 100\text{ bar}$

Transient function with stepped command value change ²⁾

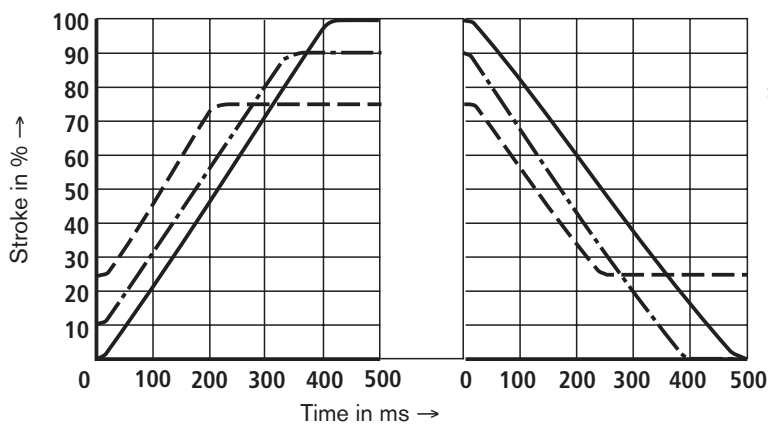

- Step responses
- 0 - 100 - 0% ———
 - 10 - 90 - 10% - · - · - · -
 - 25 - 75 - 25% - - - -

- ¹⁾ Flow values above 1200 l/min are no measured values!
- ²⁾ Measurement conditions
 Pressure in A = 50 bar
 Actuator in B closed ($p_A = p_B = 50\text{ bar}$)
 Pressure in A < 50 bar → actuating time is extended
 Pressure in A > 50 bar → actuating time is shortened
 The area ratio of the orifice spool has an influence on the actuating time as follows:
 → Command value 0 → 100%: the actuating time becomes shorter, the higher the inlet pressure and the smaller the Δp across the valve.
 → Command value 100 → 0%: The actuating time becomes shorter, the higher the inlet pressure and the higher the Δp across the valve.

Characteristic curves (measured with HLP 46 and $\vartheta_{oil} = 40 \text{ }^\circ\text{C} \pm 5 \text{ }^\circ\text{C}$)

Size 63

Leakage from A → B and B → A in dependence upon the pressure differential Δp (command value 0 V or 4 mA, resp.)

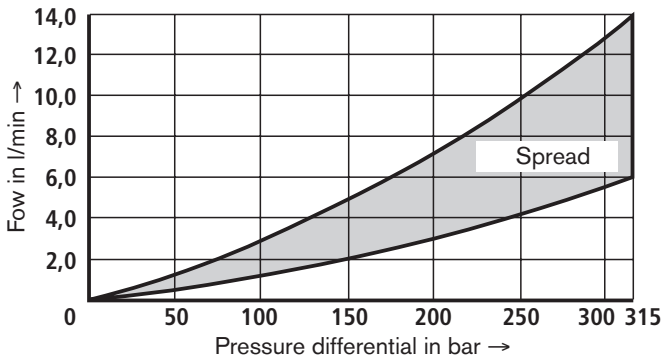

Unit dimensions: Type FES (nominal dimensions in mm)

Size	25	32	40	50	63
H11	51	63	62	73	90
H12	116	128	127	138	155
H13	110	122	121	132	149
H14	118	130	129	140	157
H15	137.5	149.5	148.5	159.5	176.5
H16	25	35	45	45	65
L1	85	102.5	126	140	180
L2	93.5	102.5	126	140	180
L3	42.5	51.25	63	70	90
L8	139	150	169	184	219
L9	15	15	15	15	15

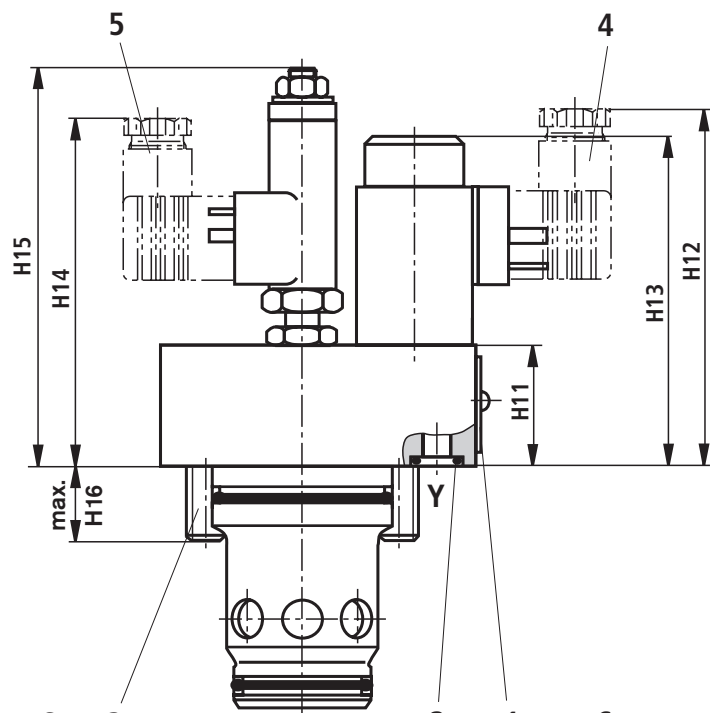

Required surface quality of mating part

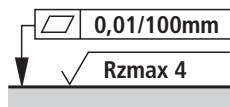

- 1 Nameplate
- 2 Identical seal rings for ports X and Y
- 3 4 off valve fixing screws to ISO 4762-10.9 (friction coefficient 0.09 ... 0.14 to VDA 235-101) are included in the scope of supply:
 Size 25: M12 x 60, tightening torque $M_T = 75 \text{ Nm}$
 Size 32: M16 x 75, tightening torque $M_T = 170 \text{ Nm}$
 Size 40: M20 x 80, tightening torque $M_T = 350 \text{ Nm}$
 Size 50: M20 x 90, tightening torque $M_T = 380 \text{ Nm}$
 Size 63: M30 x 100, tightening torque $M_T = 1200 \text{ Nm}$
- 4 Cable socket for proportional solenoid, separate order see, page 6
- 5 Cable socket for inductive position transducer, separate order, see page 6
- 6 Space required to remove cable socket

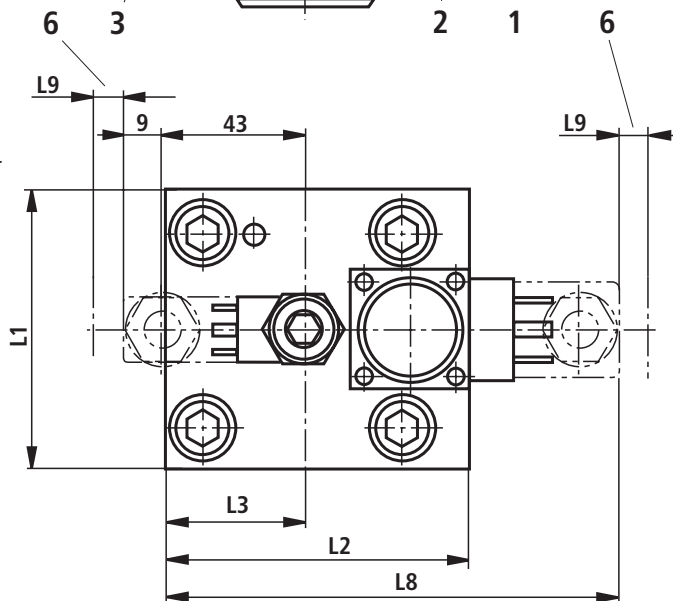

Unit dimensions: Type FESE (nominal dimensions in mm)

Size	25	32	40	50	63
H11	51	63	62	73	90
H12	116	128	127	138	155
H13	110	122	121	132	149
H16	279	291	290	301	318
H17	25	35	45	45	65
L1	85	102.5	126	140	180
L2	93.5	102.5	126	140	180
L3	42.5	51.25	63	70	90
L7	38.5	51.25	63	66	86
L8	139	150	169	184	219
L9	15	15	15	15	15
L10	10	18.75	30.5	37.5	57.5

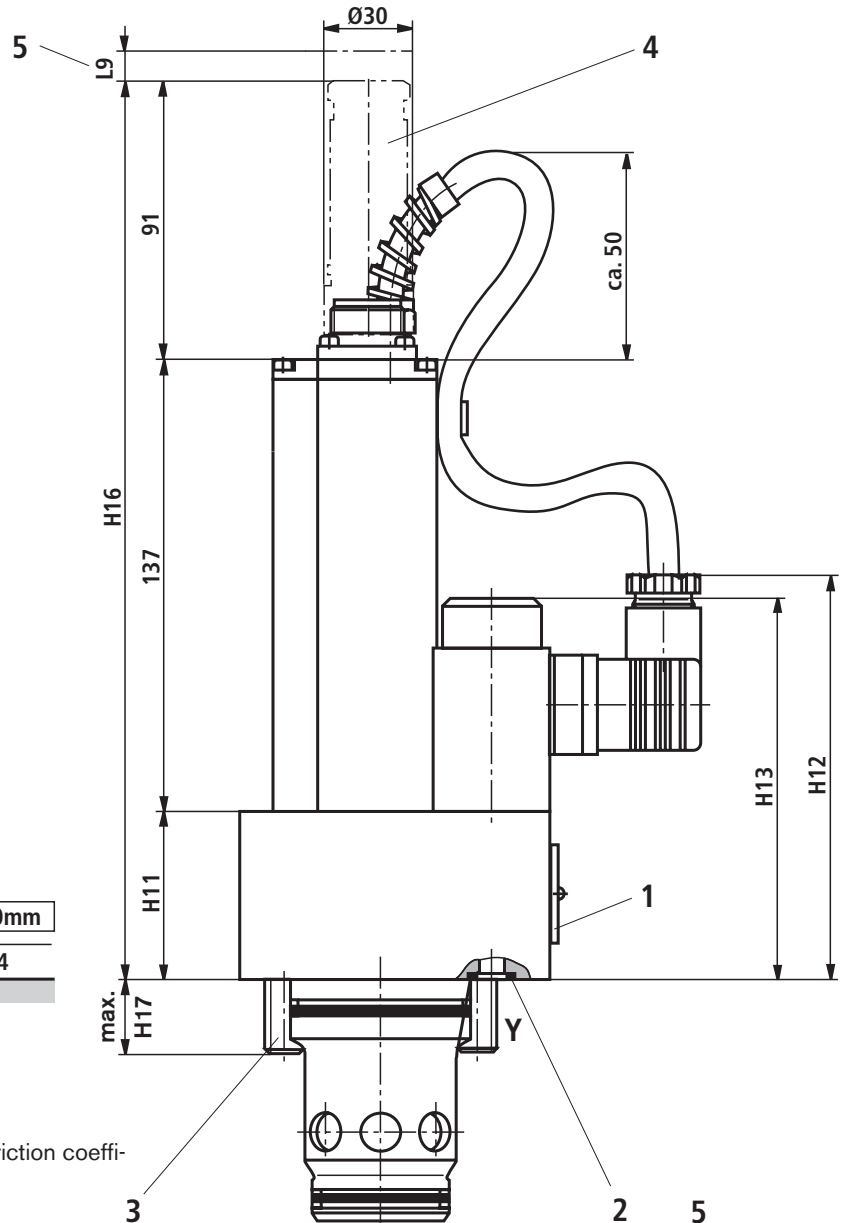

Required surface quality of mating part

- 1 Nameplate
- 2 Identical seal rings for ports X and Y
- 3 4 off valve fixing screws to ISO 4762-10.9 (friction coefficient 0.09 ... 0.14 to VDA 235-101) are included in the scope of supply:
 - Size 25: M12 x 60, tightening torque $M_T = 75 \text{ Nm}$
 - Size 32: M16 x 75, tightening torque $M_T = 170 \text{ Nm}$
 - Size 40: M20 x 80, tightening torque $M_T = 350 \text{ Nm}$
 - Size 50: M20 x 90, tightening torque $M_T = 380 \text{ Nm}$
 - Size 63: M30 x 100, tightening torque $M_T = 1200 \text{ Nm}$
- 4 Cable socket
separate order, see page 7
- 5 Space required to remove cable socket

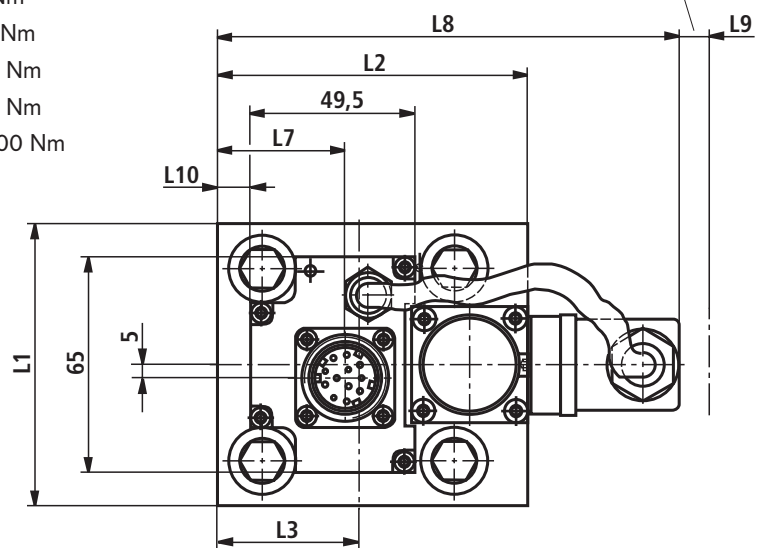

Installation dimensions (nominal dimensions in mm)

Installation dimensions to DIN ISO 7368					
Size	25	32	40	50	63
ØD1 ^{H8}	45	60	75	90	120
ØD2	25	32	40	50	63
ØD3	25	32	40	50	63
max. ØD3	32	40	50	63	80
ØD4 ^{H8}	34	45	55	68	90
D5	M12	M16	M20	M20	M30
max. ØD6	6	8	10	10	12
ØD7 ^{H13}	6	6	6	8	8
H1	44	52	64	72	95
H1 ¹⁾	40.5	48	59	65.5	86.5
H2	72	85	105	122	155
H3	58	70	87	100	130
H4	25	35	45	45	65
H5	12	13	15	17	20
H6	2.5	2.5	3	3	4
H7	30	30	30	35	40
H8	2.5	2.5	3	4	4
min. H9, (ref. dimension)	1	1.5	2.5	2.5	3
min. H10	8	8	8	8	8
L1	85	102.5	126	140	180
L2	93.5	102.5	126	140	180
L3	42.5	51.25	63	70	90
L4	58	70	85	100	125
L5	33	41	50	58	75
L6	16	17	23	30	38
L7	29	35	42.5	50	62.5

¹⁾ Bore centre at max. ØD3

Tolerances to: General tolerances ISO 2768-mK

- 7 Port X
- 8 Port Y
- 9 Locating bore for locating pin
- 10 Depth of fit
- 11 Reference dimension
- 12 Port B can optionally arranged around the central axis of port A. However, care must be taken not to drill the fixing bores and the pilot bores.
- 13 In the case of a diameter for port B other than specified in the dimensional table, the distance from the cover contact face to the centre of the bore must be calculated.

Size	Installation dimensions to DIN ISO 7368
25	ISO 7368-BB-08-2-A
32	ISO 7368-BC-09-2-A
40	ISO 7368-BD-10-2-A
50	ISO 7368-BE-12-2-A
63	ISO 7368-BF-12-2-A

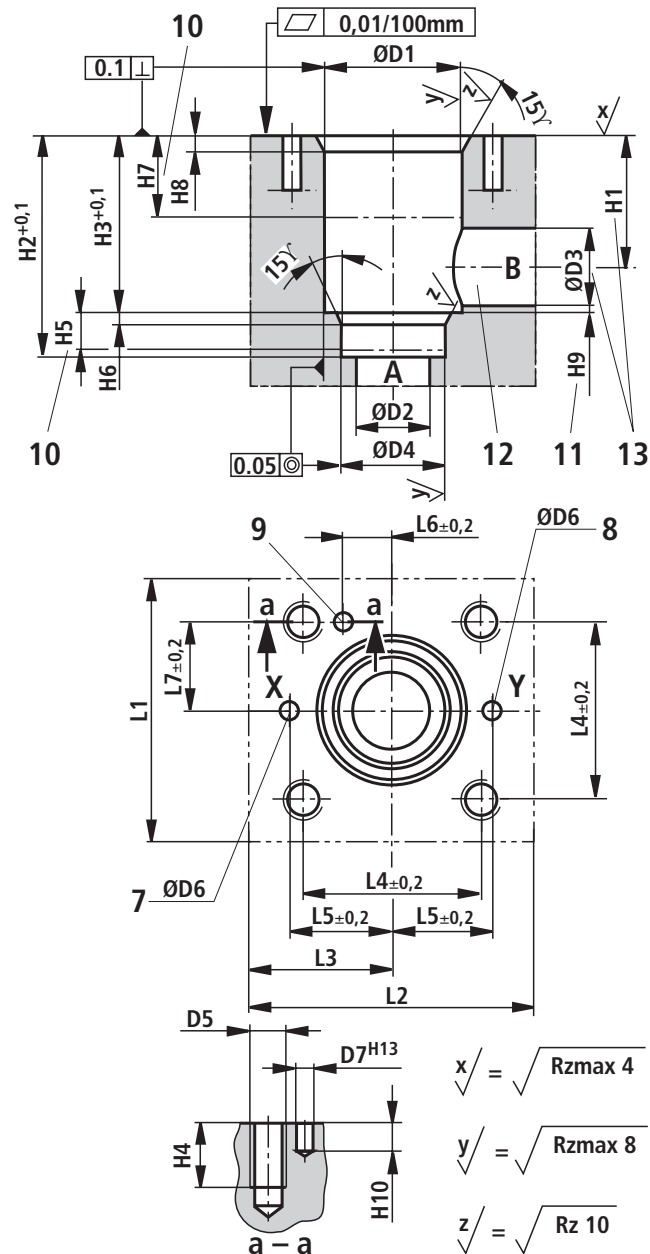

Bosch Rexroth AG
 Hydraulics
 Zum Eisengießer 1
 97816 Lohr am Main, Germany
 Phone +49 (0) 93 52 / 18-0
 Fax +49 (0) 93 52 / 18-23 58
 documentation@boschrexroth.de
 www.boschrexroth.de

© This document, as well as the data, specifications and other information set forth in it, are the exclusive property of Bosch Rexroth AG. It may not be reproduced or given to third parties without its consent.

The data specified above only serve to describe the product. No statements concerning a certain condition or suitability for a certain application can be derived from our information. The information given does not release the user from the obligation of own judgment and verification. It must be remembered that our products are subject to a natural process of wear and aging.